

# Floor Diffusers

Type FB

in aluminium and plastic

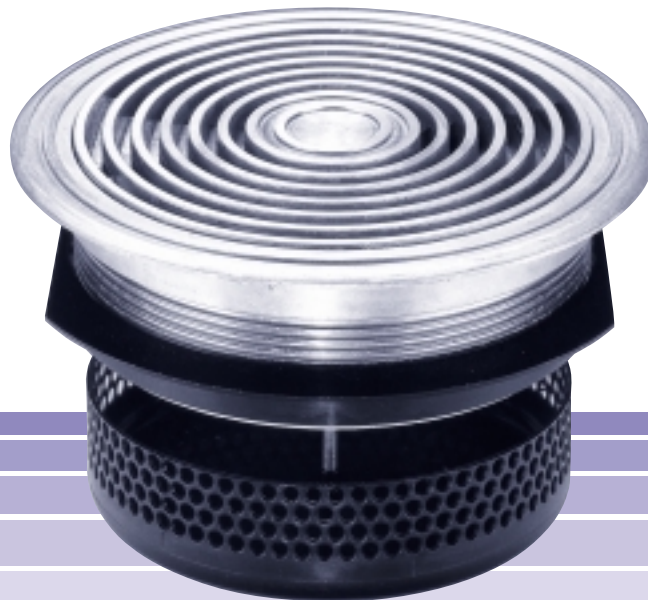

**TROX<sup>®</sup> TECHNIK**

Trox (Malaysia) Sdn.Bhd  
20 Persiaran Bunga Tanjung 1  
Senawang Land Industrial Park  
70400 SerembanNegeri Sembilan Darul Khusus  
Malaysia

Telephone +60-6-678 81 88  
Telefax +60-6-678 82 88  
[www.troxmal.com.my](http://www.troxmal.com.my)  
e-mail: [trox@troxmal.com.my](mailto:trox@troxmal.com.my)

# Contents · Description

Description _____	2	Load Capacity _____	9
Construction · Dimensions _____	3	Nomenclature · Technical Data _____	10
Dimensions GA · GAM _____	4	Acoustic Data _____	11
Installation Examples _____	5	Aerodynamic Data _____	13
Installation · Fixing Details _____	6	Technical Data Size 150 – Multiple Array _____	15
Materials _____	7	Order Details _____	16
Installation Instructions _____	8		

## FBA Construction



Where convection current effects exist in the occupied zone it is appropriate to supply air through the false floor system.

Convective currents of air can be caused by heat from people, machines or electrical equipment. Where computers and other electronic equipment are used in offices, air conditioning systems which discharge air upwards from the floor are becoming more popular. This principle allows the local heat loads to be targeted directly.

When ordering the swirl element for adjustment of discharge direction from vertical to horizontal or vice versa, Trox can preset the swirl element if the required direction of discharge is specified on the order. If adjustment of discharge direction becomes necessary on site, this can be easily carried out by turning the swirl element accordingly.

- |   |                 |
|---|-----------------|
| ① Diffuser Core   | ④ Clamping Ring |
| ② Swirl element for adjustment of air discharge direction | ⑤ Dirt Trap     |
| ③ Trim Ring   | ⑥ Plenum Box    |

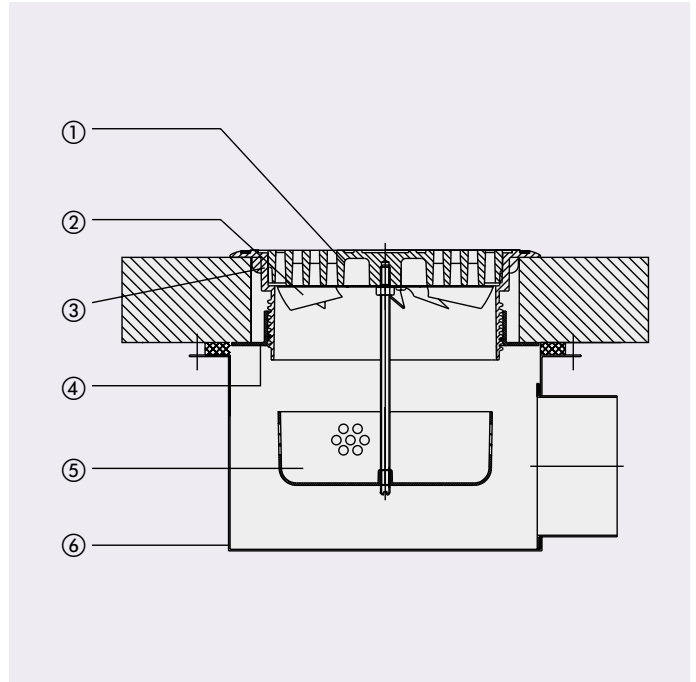

Floor diffusers are not fitted directly beneath where people sit. However, they can be used at a distance of 40 cm from seating. Floor diffusers do not cause any acoustic problems. By re-arranging working layouts, floor panels with integral diffusers can be easily replaced without major costs.

The floor diffusers offered by Trox are made in either aluminum or plastic, and form attractive design elements for architects and consultants due to the excellent variety of surface finishes and colours.

# Construction · Dimensions

## Construction

The floor diffuser core has a large number of radial ribs to produce a swirling discharge. This allows adjustment of discharge direction in critical operating conditions. The diffuser is available in aluminium or plastic. An adjustable control element is used to change the direction of discharge. There are two types of control element one adjusts discharge between vertical and horizontal (V,H) the other one provides a fixed vertical discharge (VF). The trim ring should preferably be used with carpets to prevent the edges fraying. A spacing ring is supplied on orders without trim ring for technical reasons and to adjust the height.

There are two possible configurations for orders with a dirt trap -

- with rear adjustable volume control (SM)
- with face adjustable volume control (SV)

The seal between the plenum box flange and the floor tile must be provided by the client.

Size	ØD	G	E	H <sub>1</sub>	H <sub>2</sub>	K <sub>1</sub>	K <sub>2</sub>	ØR <sub>1</sub>	ØR <sub>2</sub>	ØR <sub>3</sub>	ØR <sub>4</sub>	ØR <sub>5</sub>	c1	c2
150	98	50	160	125	71.5	200	198.5	149.5	138	137	150.1	150.3	21	22
200	123	48	200	150	84	250	248.8	199.5	188	187	200.1	200.3		

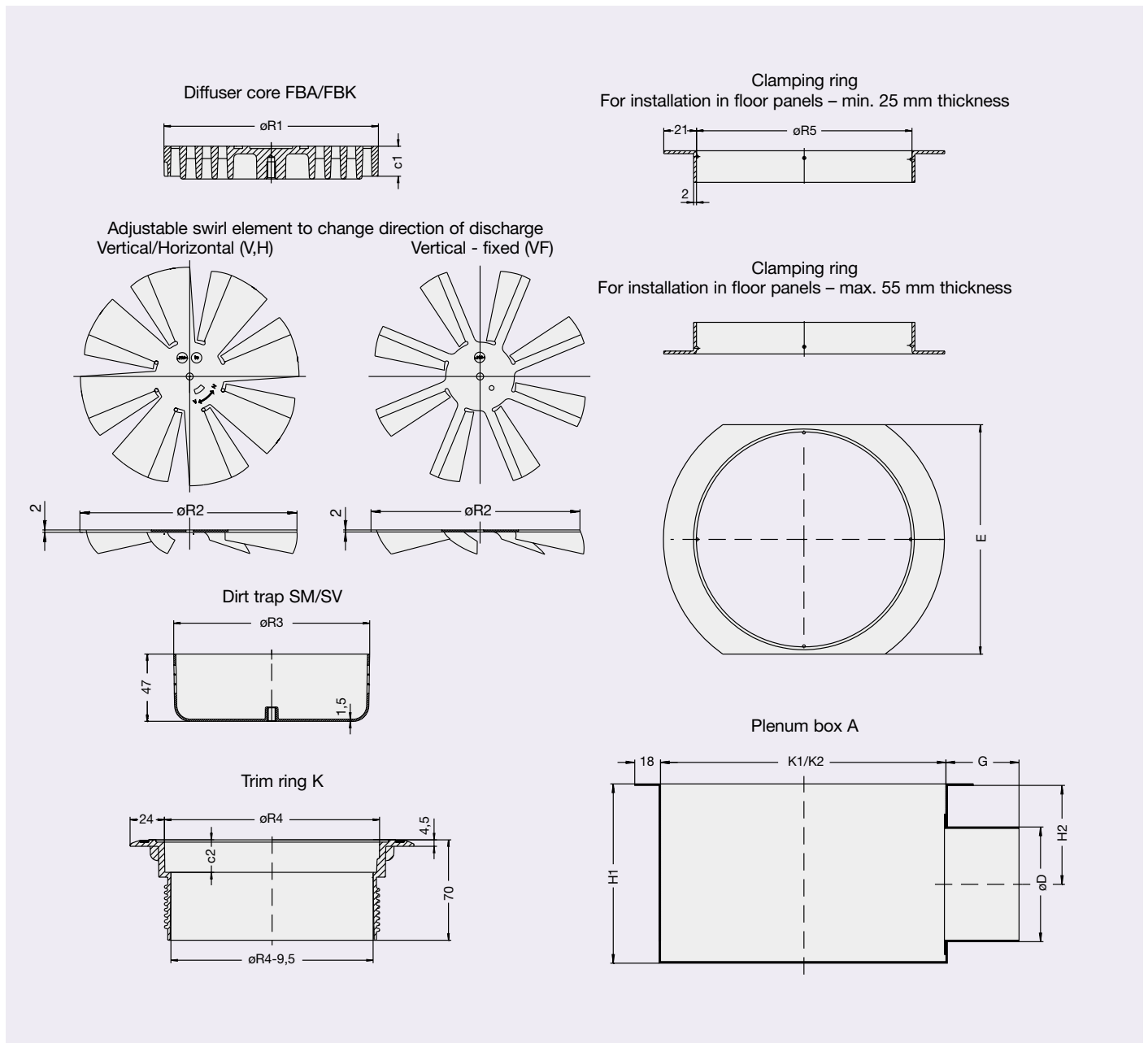

# Dimensions GA · GAM

The multiple diffuser plenum box is suitable for installation of 4 floor diffusers size 150 in the layout shown below.  
As it is not normally necessary to balance individual diffusers a damper is provided in the side entry spigot of the plenum box.

Type GA  
Multiple diffuser plenum box for 4 floor diffusers

Type GAM  
As GA, but with damper in the side entry spigot

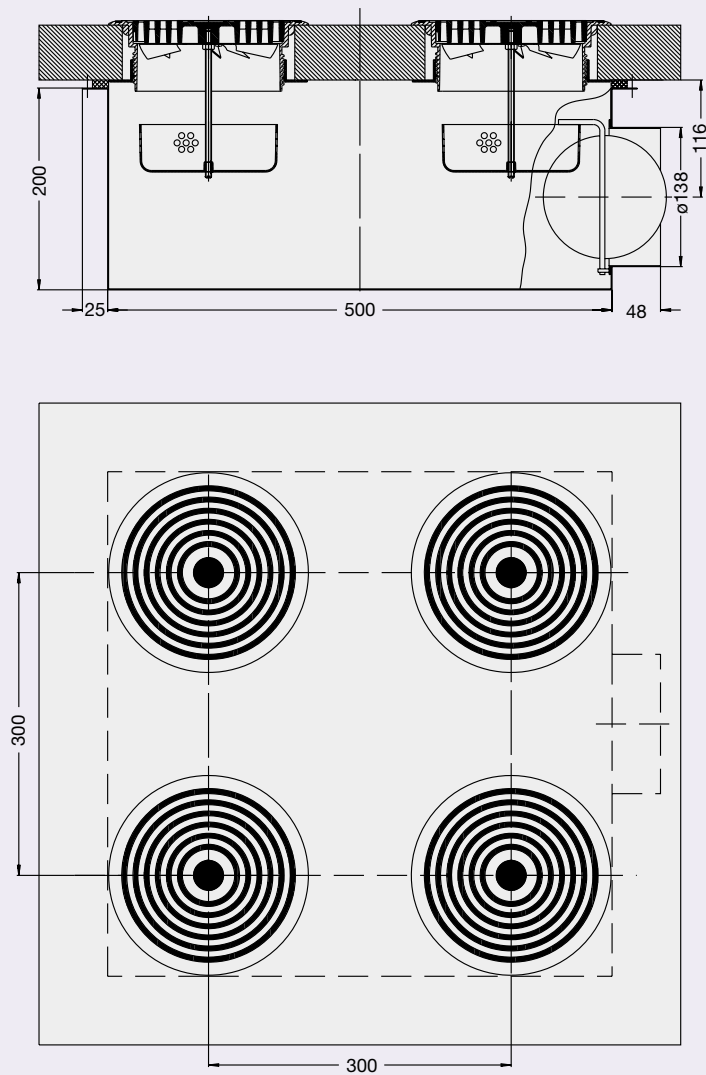

# Installation Examples

## Example 1

Positive pressure plenum floors are preferred for large areas. Here, plenum boxes are not required due to the uniform pressure distribution. If the objective is even distribution of air within the zone, it is not necessary to balance the diffusers individually.

## Example 2

The use of plenum boxes is recommended for individual room control. This guarantees that the volume flow to each room can be controlled separately, e.g. by room thermostats. For duct systems with many branches, the dirt traps are fitted with dampers to ensure an even distribution of air can be achieved.

## Example 3

For a combination of zone and individual room control, the floor diffusers for the room should have a ducted supply to the plenum boxes. The air is distributed over the zone via pressurised floor void. Individual rooms can be controlled, e.g. by room thermostats. A number of plenum boxes are shown in the example for the individual room.

## Remarks

The use of the dirt trap is dependent on the condition within the room or how the room is used. The aerodynamic performance of the diffuser is not influenced by the dirt trap.

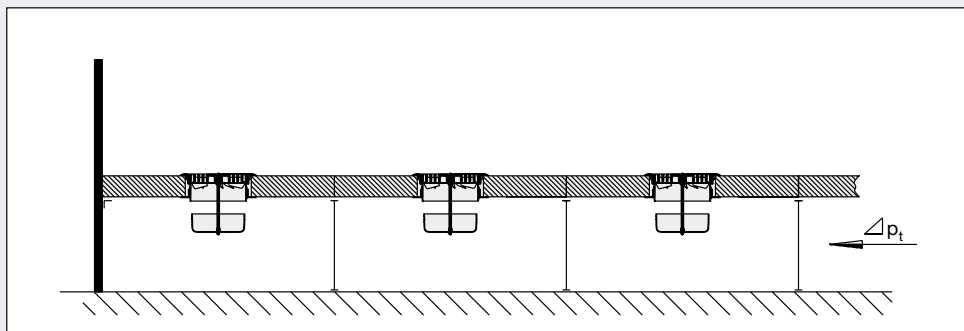

Example 1

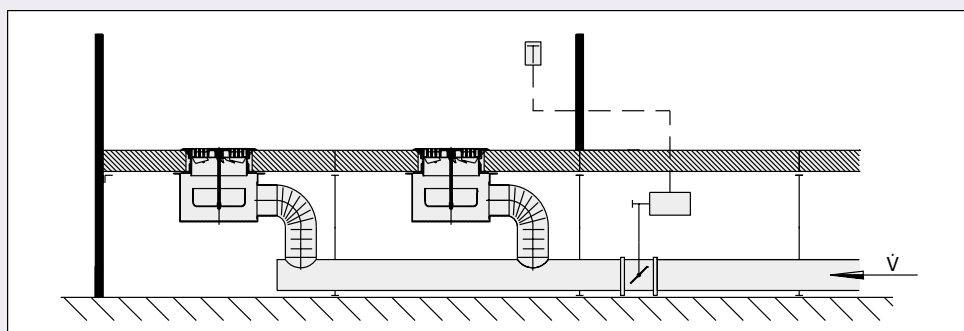

Example 2

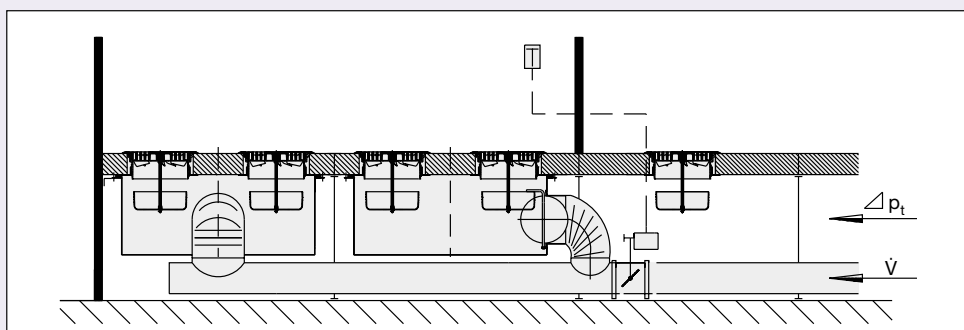

Example 3

# Installation · Fixing Details

## Installation

For installation in false floors with hard surface finishes, no trim rings are required.

The installation opening required is shown below.

A clamping ring is supplied on orders with a trim ring. The clamping ring screws onto the thread of the trim ring by means of thread sections on the clamping ring locate on the thread pitch of the trim ring.

For installation in false floors with carpet covering, trim rings should be used to protect the carpet edges. The installation opening required is shown below.

Fixing hardware is supplied for each trim ring.

The clamping devices are suitable for panel thickness from 25 to 55 mm.

On installations without a trim ring the spacing ring supplied must be fitted for technical reasons and for adjustment of the height.

Size	R <sub>6</sub>	R <sub>7</sub>	R <sub>8</sub>
150	151	143	171
200	201	193	221

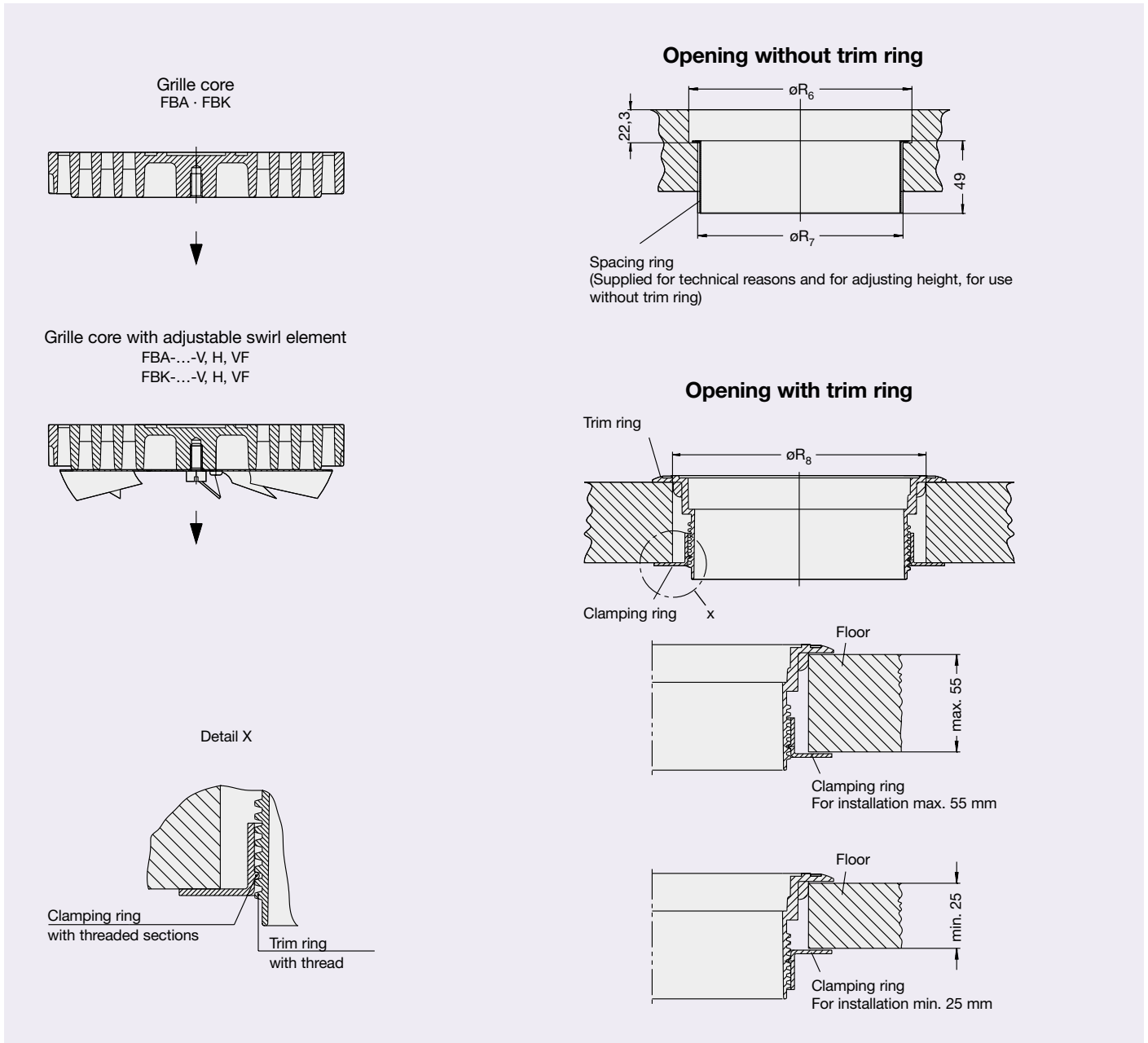

## Materials

### Construction FBA

The adjustable swirl element, the clamping ring and dirt trap are black polyamide (PA-6V) flame retardant to UL standard 94. Plenum box and volume control are galvanised sheet steel. The surface of the plenum box is phosphate treated and painted black (RAL 9005).

### Construction FBK

The floor diffuser and the trim ring are polyamide PA6 or on request, polyamide PA6-V0 in accordance with UL Standard '94 (flame resistant) and are available in the following colours: Dusty grey similar to RAL 7003; or black similar to RAL 9005. Other colours can be supplied on request. The adjustable swirl element, the clamping ring, spacing ring and dirt trap are black polyamide (PA-6V) flame retardant to UL Standard 94. Plenum box and volume control are galvanised sheet steel. The surface of the plenum box is phosphate treated and painted black (RAL 9005).

## Installation with trim ring

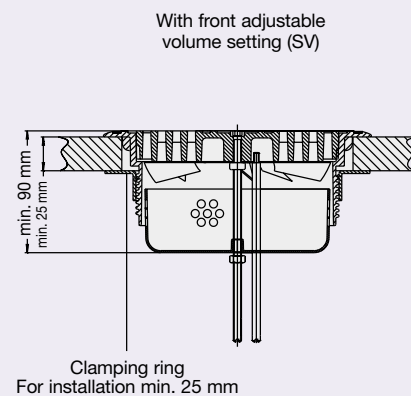
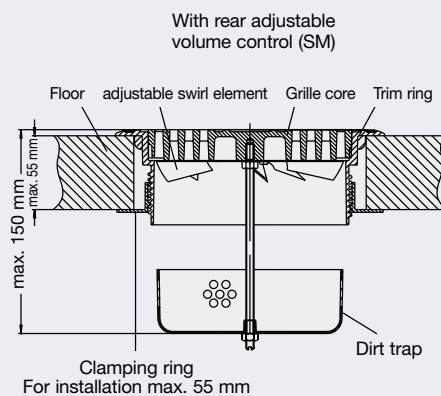

## Installation without trim ring

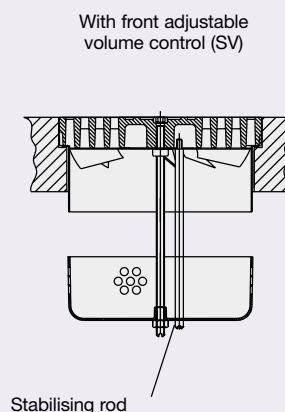
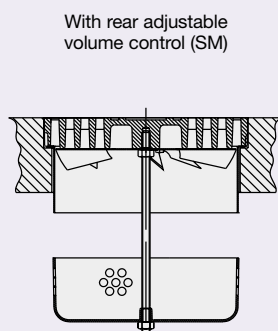

# Installation Instructions

## Installation in floors without floor tiles

For installation in floors without floor tiles the clamping ring ① is first inserted into the duct or floor void and the trim ring ② then positioned into the opening.

When fitting the clamping ring the indent sections ③ on the clamping ring and trim ring must first be positioned above each other.

Using light upwards pressure turn the clamping ring in easy stages each time starting at the indent section on the trim ring.

This guarantees easy threading of the first three thread sections ④ and after about 180° the ring will turn as a nut.

In the case of deep ducts or floor voids the trim ring can be slipped over one arm and the clamping ring held in the hand.

The arm, with both parts, can now be held with the clamping ring in the opening so that the trim ring slips down from the arm and slides into the opening.

The clamping ring can then be screwed into position as described above.

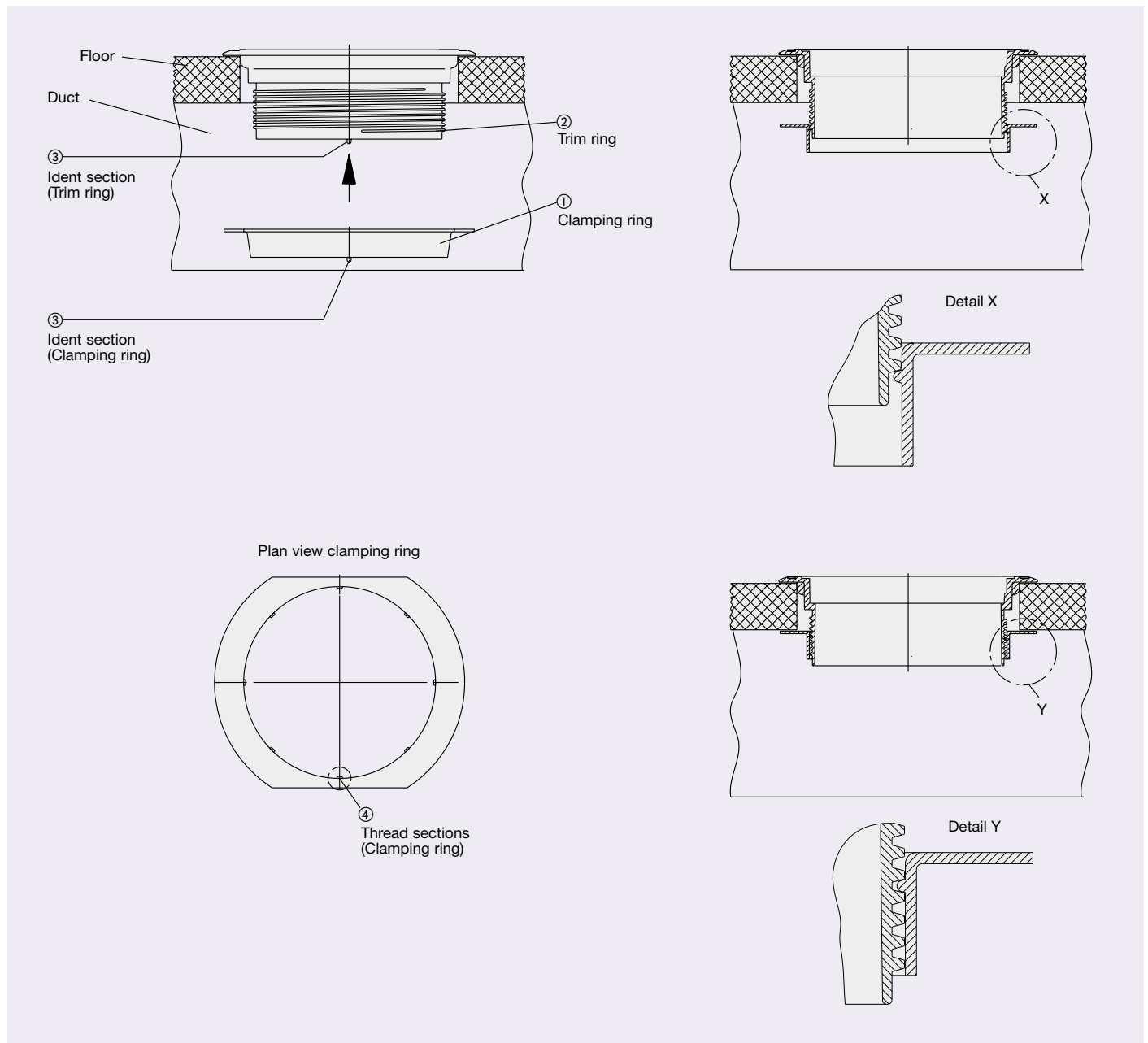



# Load Capacity

Construction		Breaking load in kN	
		Position of cube 1	Position of cube 2
Aluminium	Size 150 without trim ring	27	15
	Size 200 without trim ring	25	8
	Size 150 with trim ring	28	14
	Size 200 with trim ring	22	9
Plastic	Size 150 without trim ring	15	7
	Size 200 without trim ring	6	3
	Size 150 with trim ring	12	6
	Size 200 with trim ring	6	2

**Load capacity with trim ring**

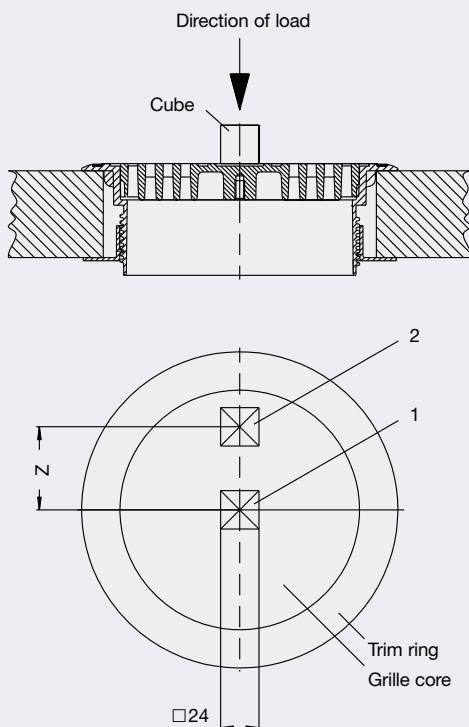

**Load capacity without trim ring**

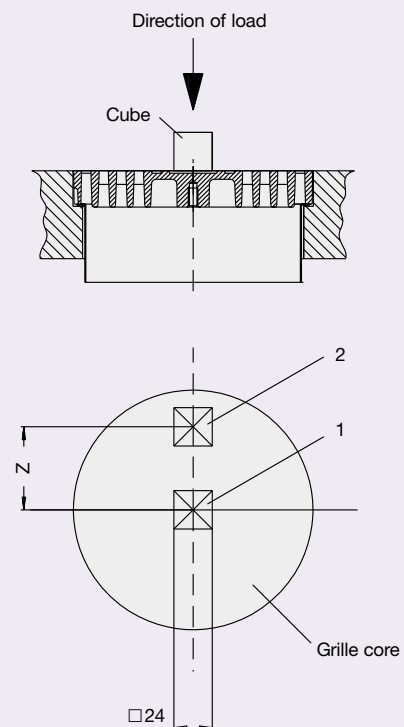

Size	Z
150	52
200	77

# Nomenclature · Technical Data

**Note:**

For construction without the control element the aerodynamic data for the diffuser with vertical discharge only are applicable.

**Nomenclature**

- $\dot{V}$  in l/s: Volume flow per diffuser
- $\dot{V}$  in m<sup>3</sup>/h: Volume flow per diffuser
- L in m: Distance from centre of diffuser
- y in m: Height of measuring point 10-50 mm above floor level
- $h_1$  in m: Height above diffuser
- $h_{max}$  in m: Max. penetration height of supply air jet depending on  $\Delta t_z$  or  $\dot{V}$
- $v_{eff}$  in m/s: Effective jet velocity
- $\bar{v}_L$  in m/s: Max. time average air velocity in 10-50 mm above floor level
- $\bar{v}_{H1}$  in m/s: Max. time average air velocity at height  $h_1$  above floor level
- $\Delta t_z$  in K: Temperature difference between supply air and room air
- $\Delta t_{h1}$  in K: Difference between room and core temperature at height  $h_1$
- $\Delta t_L$  in K: Difference between room and core temperature at distance L
- $\Delta p_t$  in Pa: Total pressure drop
- $L_{WA}$  in dB(A): A-weighted sound power level
- $L_{WNC}$  : NC rating of sound power level
- $L_{WNR}$  :  $L_{WNR} = L_{WNC} + 1$
- $\Delta L$  in dB/Oct.: Relative sound power level with respect to  $L_{WA}$
- $L_{pA}, L_{pNC}$  : A-weighting and NC rating respectively of room sound pressure level  
 $L_{pA} \approx L_{WA} - 8 \text{ dB}^*$   
 $L_{pNC} \approx L_{WNC} - 8 \text{ dB}^*$
- $L_W$  in dB/Oct.: Octave sound power level of flow regenerated noise  $L_W = L_{WA} + \Delta L$

\* Room absorption

Air discharge: Vertical

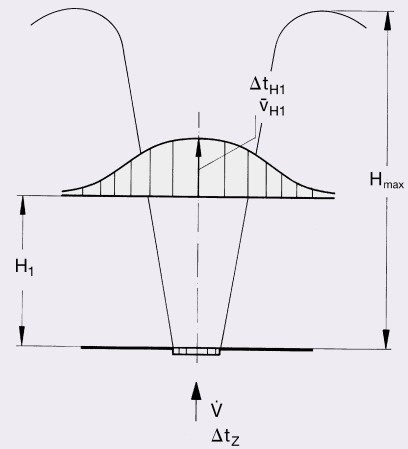

Air discharge: Horizontal

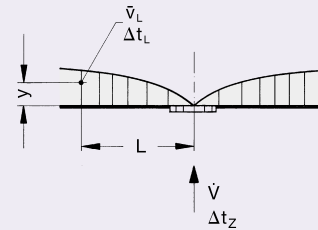

**Effective free area  $A_{eff}$  in m<sup>2</sup>**

Size	150	200
Vertical discharge (V)	0.00394	0.00560
Horizontal discharge (H)	0.00334	0.00560
Vertical - fixed (VF)	-	0.00820

# Acoustic Data

Air discharge: Vertical

Correction to Diagram 1  
Volume control using dirt trap

open	$\Delta p_t$	$L_{WA} / L_{WNC}$ without AK	$L_{WA} / L_{WNC}$ with AK
100%	x 1.0	-	-
40%	x 1.4	+ 4	+ 2
20%	x 2.3	+ 8	+ 7

Correction to Diagram 2  
Volume control using dirt trap

open	$\Delta p_t$	$L_{WA} / L_{WNC}$ without AK	$L_{WA} / L_{WNC}$ with AK
100%	x 1.0	+ 0	+ 0
40%	x 1.3	+ 3	+ 0
20%	x 2.0	+ 7	+ 6

Correction to Diagram 3  
Volume control using dirt trap

open	$\Delta p_t$	$L_{WA} / L_{WNC}$ without AK	$L_{WA} / L_{WNC}$ with AK
100%	x 1.0	+ 0	+ 0
40%	x 1.3	+ 3	+ 3
20%	x 2.0	+ 7	+ 7

Correction to Diagram 4  
Volume control using dirt trap

open	$\Delta p_t$	$L_{WA} / L_{WNC}$ without AK	$L_{WA} / L_{WNC}$ with AK
100%	x 1.0	+ 0	+ 0
40%	x 1.7	+ 6	+ 6
20%	x 3.5	+ 15	+ 7

**Note:**

The aerodynamic data for the discharge of air applies to constructions without adjustable swirl elements: discharging vertically!

1 Sound power and pressure drop  
FBK · Size 150

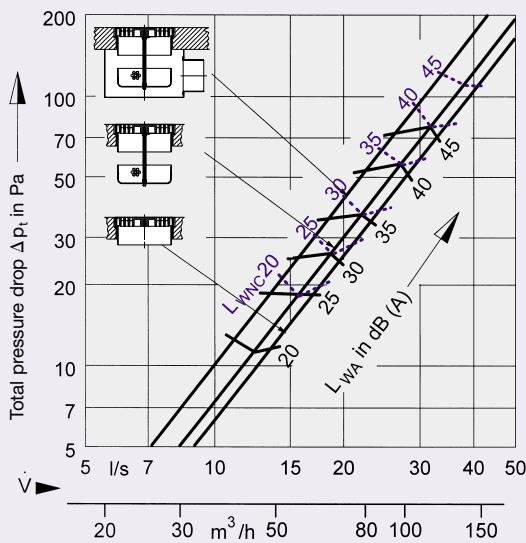

3 Sound power and pressure drop  
FBA/FBK · Size 200

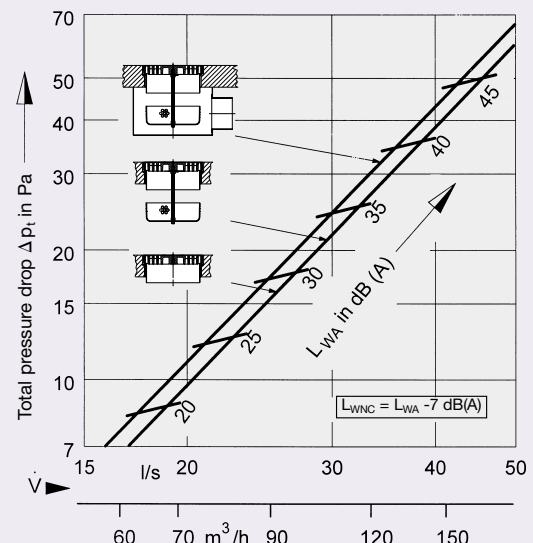

2 Sound power and pressure drop  
FBA · Size 150

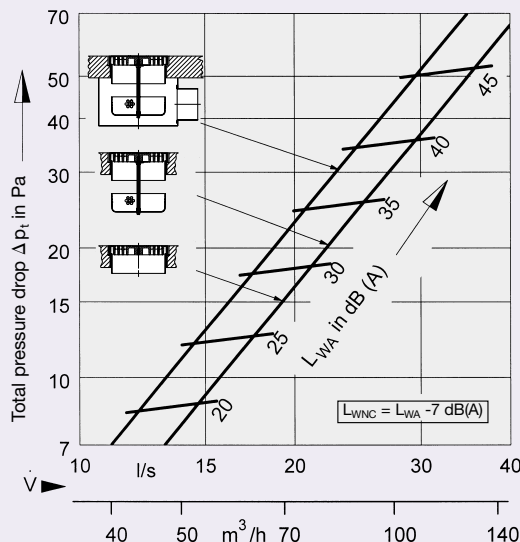

4 Sound power and pressure drop  
FBA/FBK · Size 200 vertical - fixed (VF)

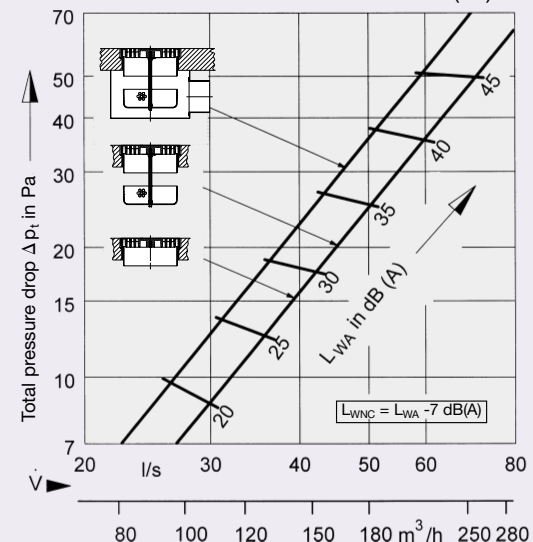

# Acoustic Data

Air discharge: Horizontal

## Example

Given:

Type FBA - H - SM / 200

Volume control

20% open

Volume flow

$\dot{V} = 35$  l/s

Required:

Octave sound power level of regenerated noise  $L_W$

Diagram 7:

$$L_{WA} = 37 + 7 = 44 \text{ dB(A)}$$

$$\Delta p_t = 36 \times 1.7 = 61 \text{ Pa}$$

## Effective discharge velocity $v_{\text{eff}}$ :

$$v_{\text{eff}} = \frac{\dot{V}}{A_{\text{eff}} \cdot 1000} = \frac{35}{0.0056 \cdot 1000} = 6.3 \text{ m/s}$$

$$v_{\text{eff}} = 6 \text{ m/s}$$

**5** Sound power and pressure drop FBK · Size 150

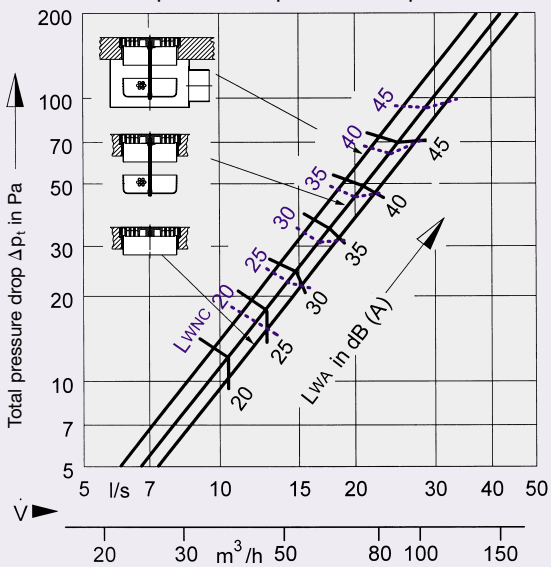

Correction to Diagram 5

Volume control using dirt trap

open	$\Delta p_t$	$L_{WA} / L_{WNC}$	
		without AK	with AK
100%	x 1.00	-	-
40%	x 1.20	+ 3	+ 2
20%	x 2.00	+ 5	+ 4

Correction to Diagram 6

Volume control using dirt trap

open	$\Delta p_t$	$L_{WA} / L_{WNC}$	
		without AK	with AK
100%	x 1.00	+ 0	+ 0
40%	x 1.15	+ 1	+ 0
20%	x 1.50	+ 4	+ 4

Correction to Diagram 7

Volume control using dirt trap

open	$\Delta p_t$	$L_{WA} / L_{WNC}$	
		without AK	with AK
100%	x 1.00	+ 0	+ 0
40%	x 1.25	+ 3	+ 2
20%	x 1.70	+ 7	+ 6

**6** Sound power and pressure drop FBA · Size 150

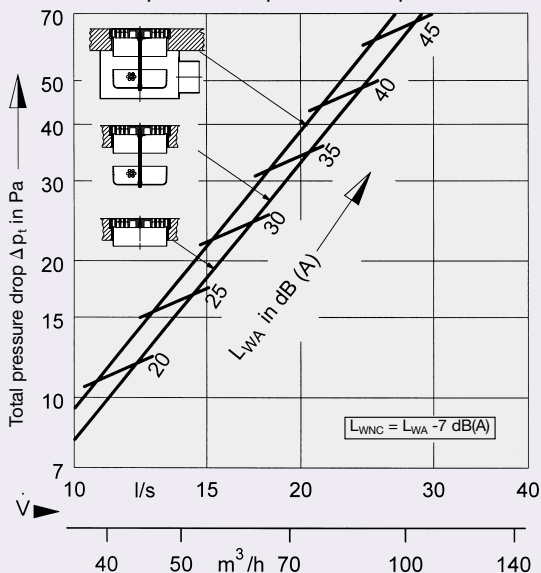

**7** Sound power and pressure drop FBA/FBK · Size 200

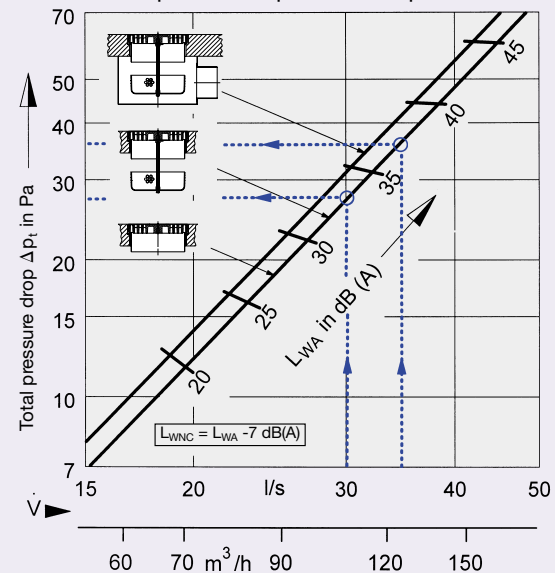

# Aerodynamic Data

Air discharge: Vertical

Diagram 8, 9 and 10 refer to  $\Delta t_z = -6 \text{ K}$ .

Correction values for other supply air temperature differentials

$\Delta t_z$ (K)	-4	-6	-8	-10
$H_{\max}$ (m)	x 1.2	x 1.0	x 0.85	x 0.75
$\bar{v}_{H1}$ (m/s)	x 1.2	x 1,0	x 0.85	x 0.75

Setting the adjustable swirl element

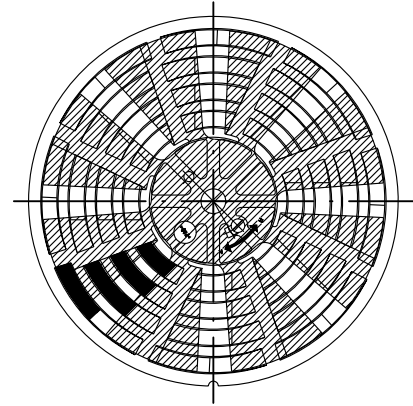

**Note:**

For construction without the control element the aerodynamic data for the diffuser with vertical discharge only are applicable.

**8** Air velocity  
FBK · Size 150

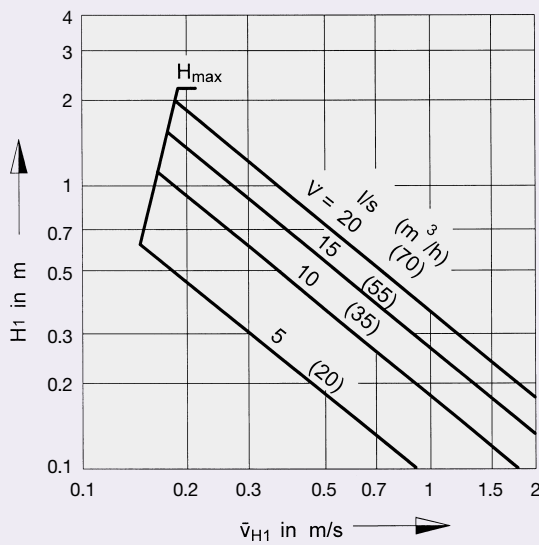

**10** Air velocity  
Size 200

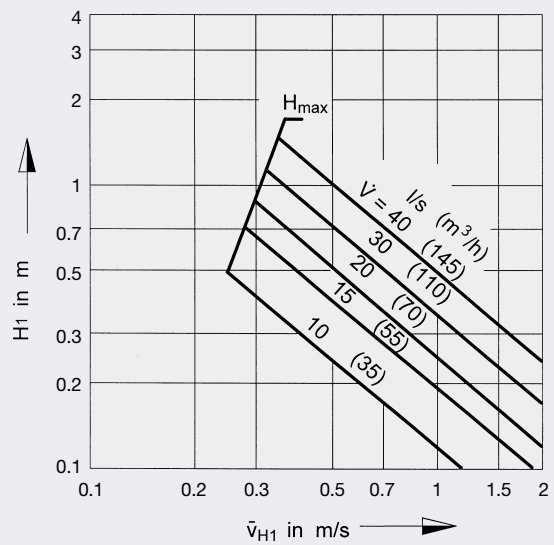

**9** Air velocity  
FBA · Size 150

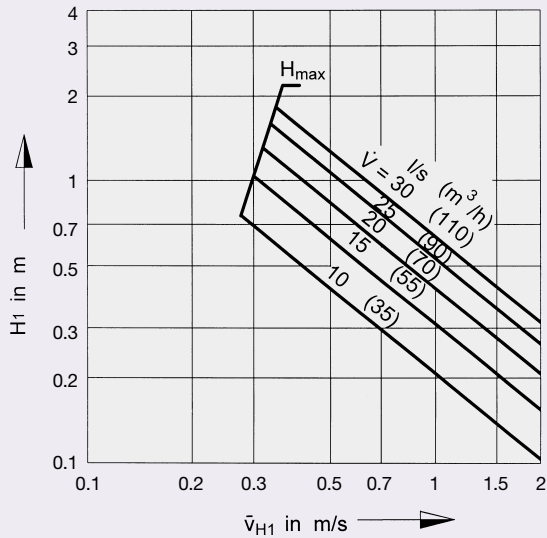

**11** Temperature quotient

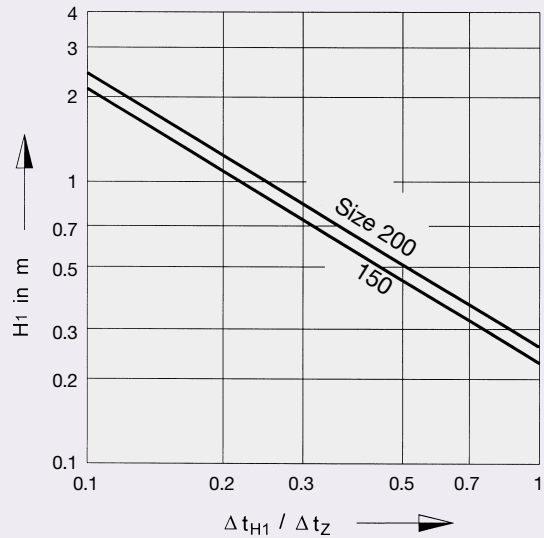

# Aerodynamic Data

Air discharge: Horizontal

## Example

Given:

Type FBA-2-H-K-SM/200

Volume flow

$$\dot{V} = 30 \text{ l/s}$$

Supply air temperature differential

$$\Delta t_z = -6 \text{ K}$$

Distance from centre of diffuser

$$L = 0.7 \text{ m}$$

Diagram 7:

$$L_{WA} = 33 \text{ dB(A)}, (L_{WNC} = 26 \text{ NC})$$

$$\Delta p_t = 27 \text{ Pa}$$

Diagram 14:

$$\Delta t_L = 0.23 \times (-6 \text{ K}) = -1.4 \text{ K}$$

$$\text{max. air velocity } \bar{v}_L = 0.26 \text{ m/s}$$

From diagram 15:

aerodynamic data

$$\Delta t_L / \Delta t_z = 0.23$$

## Setting the adjustable swirl element

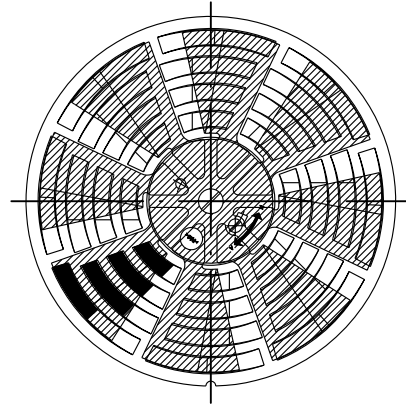

**12** Aerodynamic data FBK Size 150

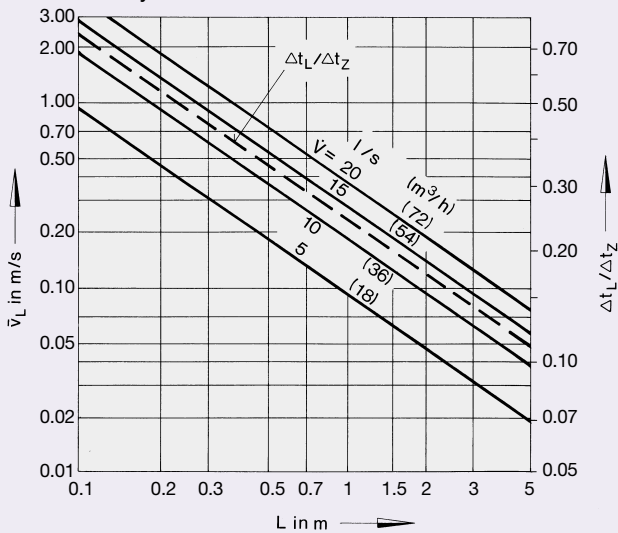

**14** Aerodynamic data Size 200

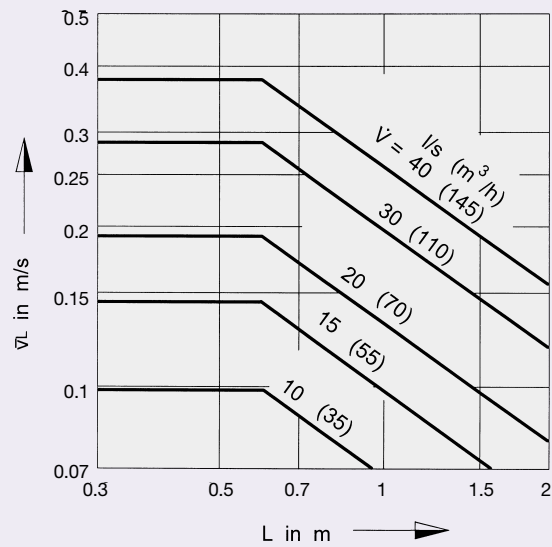

**13** Aerodynamic data FBA Size 150

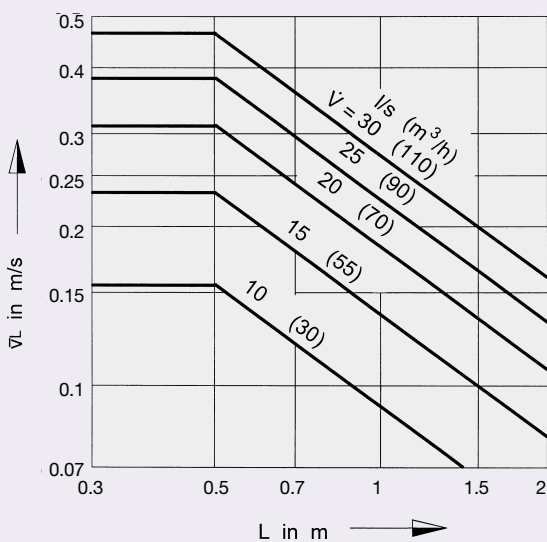

**15** Temperature quotient

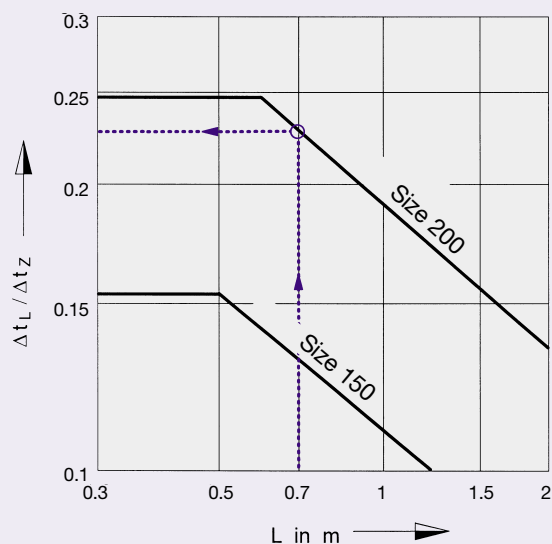

# Technical Data Size 150 · Multiple Array

Air discharge: Vertical

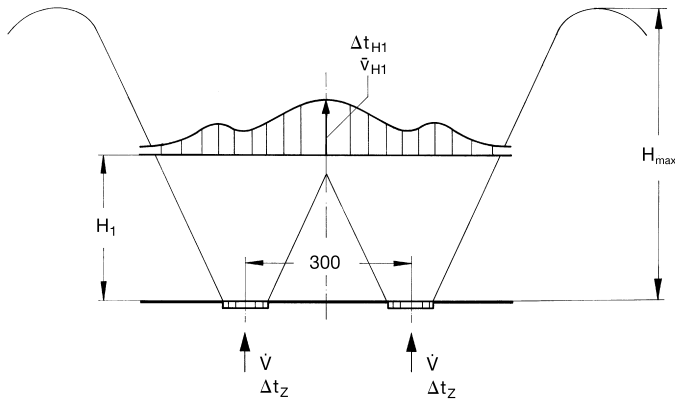
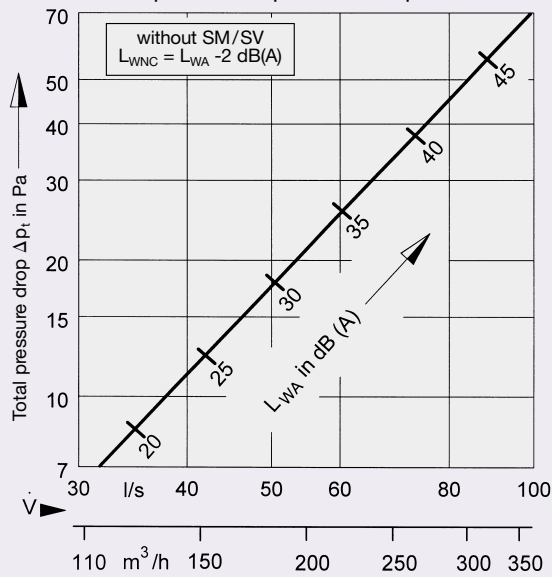

Diagram 17 refers to  $\Delta t_z = -6 \text{ K}$ .

Correction values for other supply air temperature differentials

$\Delta t_z$ (K)	-4	-6	-8	-10
$H_{\max}$ (m)	x 1.2	x 1.0	x 0.85	x 0.75
$\bar{v}_{H1}$ (m/s)	x 1.2	x 1.0	x 0.85	x 0.75

16 Sound power and pressure drop



Correction to diagram 16

Damper inside entry spigot

Damper "opening"	$\Delta p_t$	$L_{WA}/L_{WNC}$
90°	x 1.0	+ 0
45°	x 1.6	+ 2
0°	x 4.1	+ 5

17 Air velocity

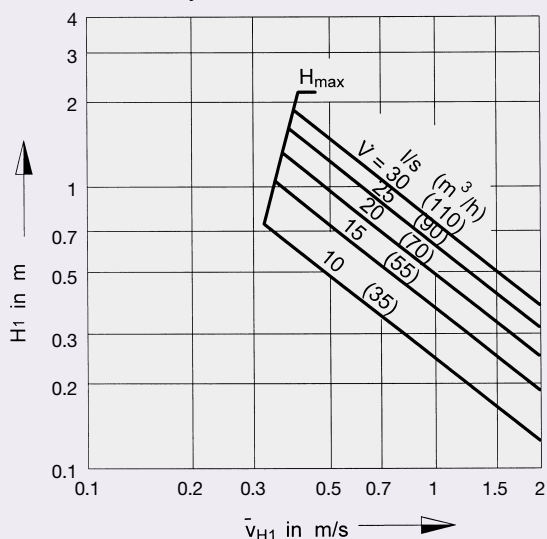

18 Temperature quotient

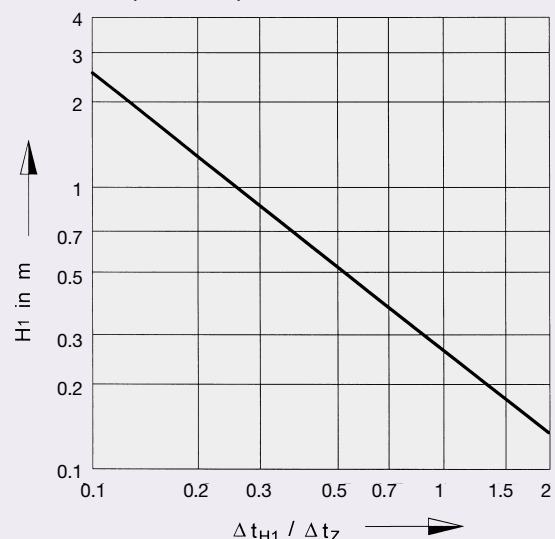

# Order Details

## Specification Text

Floor diffuser suitable for installation in false floors. The swirling type discharge ensure acceptability in critical operating conditions. Due to high induction, the core jet velocity and supply temperature differential rapidly reduce. The floor diffuser has a large number of radial ribs to produce a swirling discharge. The adjustable swirl element is turned to alter the direction discharge between vertical and horizontal. Different elements are used for vertical/horizontal (VH) or fixed vertical (VF) discharge. The trim ring is used with fitted carpets, to prevent the edges fraying. Depending on room use and application dirt traps and plenum boxes can be used. For construction with a dirt trap the air volume can be controlled at the face or at the rear of the floor diffuser.

## Materials FBA:

Die cast aluminium floor grille and trim ring. There are four different surface treatments (see order code), adjustable swirl element, clamping ring, dirt trap and spacing ring are black polyamide (PA 6-V) to UL Standard '94 (flame retardant). Galvanized sheet steel plenum box and volume control damper. The surface of the plenum box is phosphate treated and stove-enamelled black (RAL 9005). For breaking load see page 9.

## Materials FBK:

Polyamide (PA 6 or PA6-V) floor grille and trim ring to UL Standard '94 (flame retardant) and available in the following colours: dusty grey – similar to RAL 7030; black similar to RAL 9005. Other colours available on request. Black Polyamide (PA 6-V) adjustable swirl element, clamping ring, spacing ring and dirt trap to UL Standard '94 (flame retardant). For load capacity see Page 9. Galvanized sheet steel plenum box and volume control damper. The surface of the plenum box is phosphate treated and stove-enamelled black (RAL 9005).

## Order Code

### Aluminum Construction

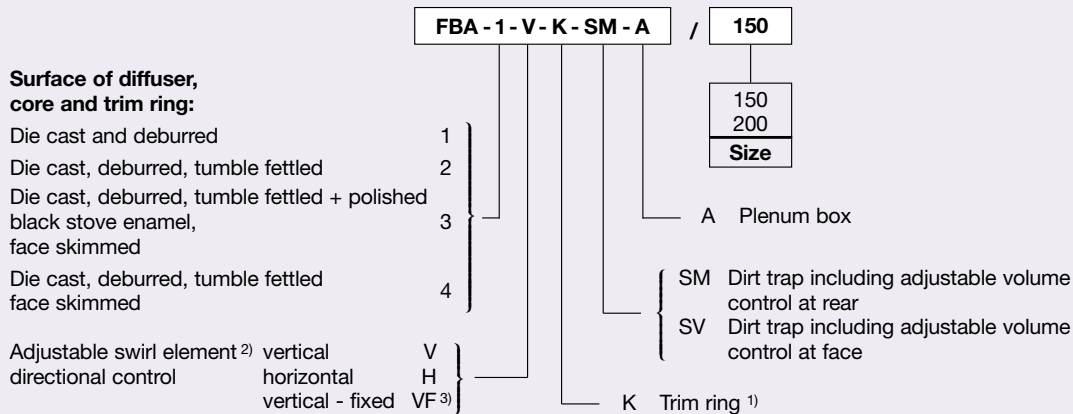

### Plastic Construction

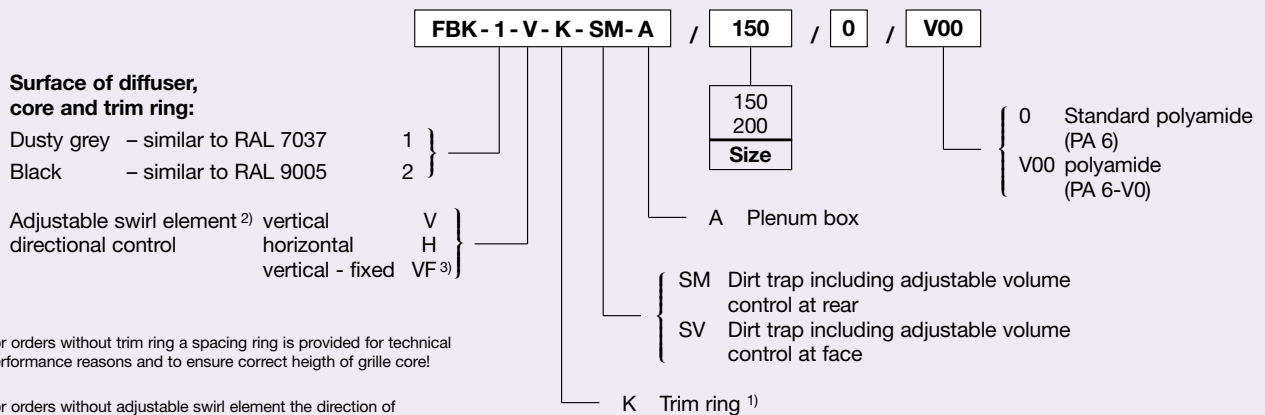

1) For orders without trim ring a spacing ring is provided for technical performance reasons and to ensure correct height of grille core!

2) For orders without adjustable swirl element the direction of air discharge is vertical!

3) Not available for size 200!

## Order Example FBA

Make: TROX  
 Type: FBA - 3 - V - K - SV - A / 200

## Order Example FBK

Make: TROX  
 Type: FBK - 1 - V - K - SM - A / 150 / 0 / V00

## Accessories for type FBA and FBK Size 150:

**GA** Multiple diffuser plenum box for 4 floor diffusers  
**GAM** as GA, but with damper in side entry spigot