

NETFLOR[®] CamassCrete System

— Low Profile Cable Management System

CamassCrete® Low Profile Cable Management Access Floor

CamassCrete® system is a breakthrough in access floor technologies. The system is an achievement and new development amongst **Netfloor's Camass®** product family. In addition to the traditional access floor's fundamental functions such as heavy load bearing, high cable capability, CamassCrete® facilitates "User Friendly" approaches on "low profile", "user accessibility" and "systematic cable trench system", which are generally required at office and school environments nowadays.

FEATURES AND BENEFITS

Cable Trench System: The Reticulated Cable Trench System offers high accessibility to office users. Trench Caps to cover the cable trenches are easily lifting and installing. No special tools are needed. Through Cable Trenches, power, data and voice wires are easily extended or connected to furniture, partition and workstations. Basic expansion, re-routing, relocation of cables and utility boxes, can be done by the office people easily and quickly without calling for help of professionals.

Stability: UniPanels (main panel) is structured with 4 built-in pedestals at four corner of the panel. In the event of earthquake or unusually strong impact, the system will not be collapsed.

Safety to end-users: When rerouting cables or relocating outlet boxes, the office user just lifts the Cable Trench caps or UniPanels by hand. If the office is installed with traditional access floor, the user has to use special tool such as panel lifter to lift the panel, which is steel/cement structured and normally weighted 13 to 16 kg per piece. It is not safe to operate by office people and may cause hazard.

Low Profile, **without sacrifice ceiling height:**

- One of the key features of **CamassCrete®** is the system is competent to install at **low profile under 10 cm**. Standard heights of **CamassCrete® CR1000** series are 4 cm, 5 cm, 6 cm, 7.6 cm and 10 cm, the heights which traditional raised floor are not suitable to be installed.
- **CamassCrete® CR1500** series are available for height between 10 cm to 15 cm. CR1500 series are designed to meet requirement at new office buildings as well as corporate headquarters, where ceiling height is not a problem, and to provide extra large cable capability and high, efficient accessibility to office users.

THE SYSTEM --- CamassCrete® CR1000 and CR1500 Series

The system is composed of 4 main components: UniPanel (main panel), Base Connector, Central Cap and Flank Cap.

For installing below 10 cm (4"), **CamassCrete®** are available in 5 standard heights.

CR1000-40: height 4 cm (1.57")

CR1000-50: height 5 cm (1.97")

CR1000-60: height 6 cm (2.36")

CR1000-76: height 7.6 cm (3")

CR1000-100: height 10 cm (4")

For installing higher than 10 cm (4"), CR1500 series is designed for higher cable capability.

CR1500: For installing height at 10 cm ~ 15 cm



UniPanel (Main Panel)



Base
Connector

Central
Cap

Flank Cap



Base Connector to connect pedestals standard 9 cm distance grid-form Cable Trenches formed automatically

Description of Main Components

UniPanel (main panel): Steel in-filled with light weight cement, powder coating. Pedestals are fixed at four corners of the panel.

For CR1000 series, pedestals are fixed height and factory assembled.

For CR1500 series, the pedestals are provided separately and fixed at the job site.

Base Connector, Central Cap and Flank

Cap: are made of steel with corrosion resistance protection

Interlocking by Base Connector: To install, use Base Connector to connect pedestals of the UniPanels. Connecting the UniPanels is easy, with no gluing, nailing or drilling required.

Cable Trenches: Continuous connection of UniPanels, standard-distance grid-form cable trenches formed automatically.

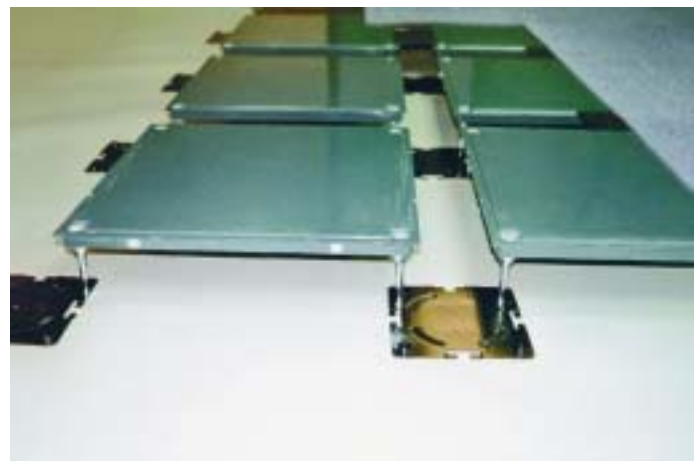

RETICULATED CABLE TRENCH SYSTEM --- Easy Routing Of Cables And Fully Accessible

Reticulated Cable Trench is main feature of **CamassCrete®**. The grid pattern cable trench system provides systematic, easy routing and extension of cables. The trench caps to cover the cable trenches shall be installed before or after routing of cables. As all UniPanels are self-standing, lifting or replacing of trench caps are safe, convenient and without resorting to special tools.

"LOW-PROFILE" INSTALLATION --- To Install At Limited Height Of Below 10 cm (4")

To install below 10 cm (2.36"), the system is installed by following the floor contours. Cable trenches have effectively absorbed the uneven sub-floor and trenches' clearance is maintained at steady height. **CamassCrete®** product family is the only access floor system capable to install at below 10 cm (4") while retain steady height at the cable trenches for cable routing.

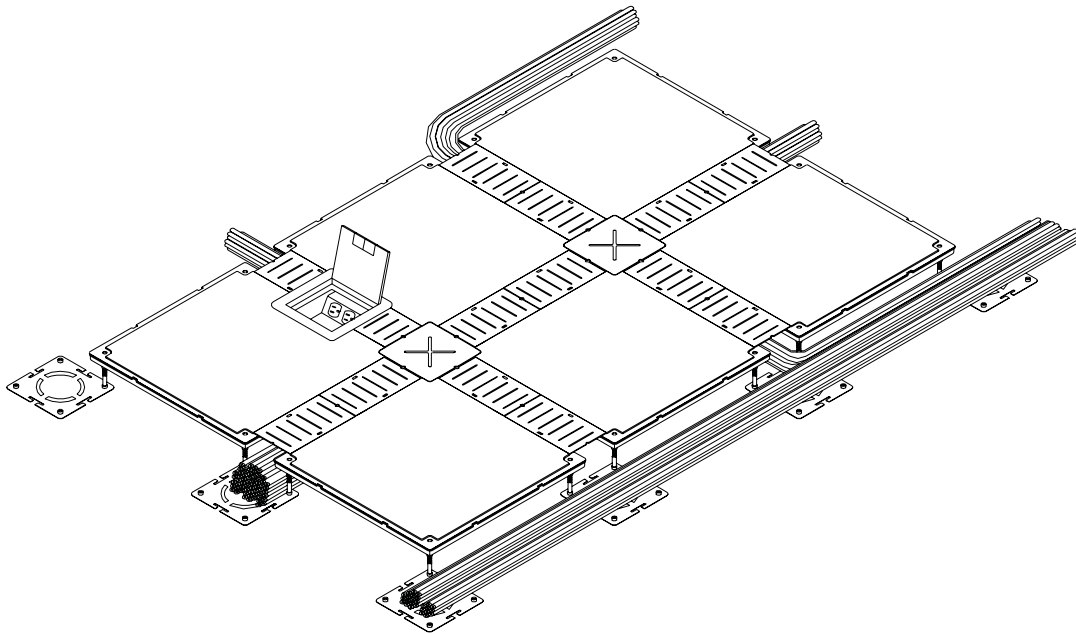
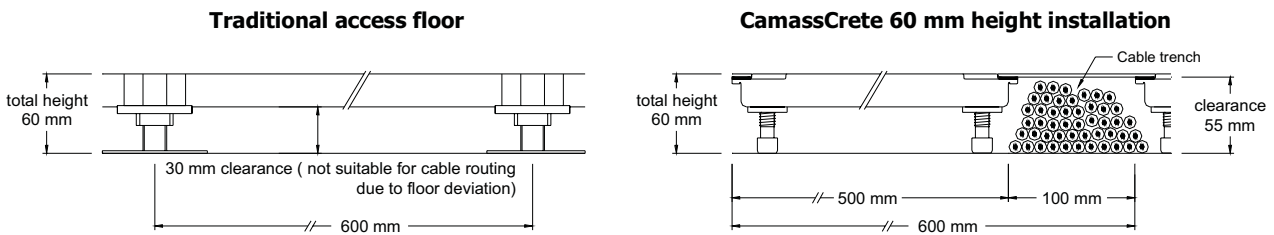

IDEAL FOR RENOVATION IN OLD BUILDING AS WELL AS IN NEW OFFICE

Low-profile, accessibility, quiet and quick installation are concerned in case of old office renovations. In real retrofit project, **CamassCrete®** are often installed on top of old floor trunk, carpet, sheet vinyl, and etc.

Old cable trunk or embed ducts are not workable anymore. The picture shown below was 6 cm (2.36") high **CamassCrete®** system to install on top of old floor trunks.

For new offices, **CamassCrete®** is ideal for easy and organized cable routing, users accessibility, flexible for future expansion and changes



FLEXIBLE OPTIONS FOR DATA & POWER EXTENSION AND CONNECTIONS

To organize efficient cable routing, extension to cable contractor and friendly accessibility to office user, **CamassCrete®** provides convenient and flexible options.

1. Through Cable Trenches



Exit Cap + grommet to replace Flank Cap and cable extends through the 6 cm diameter opening

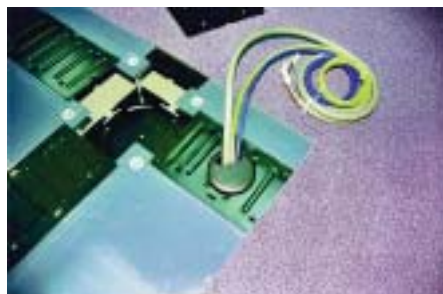

Cable extension from Exit Cap to extend to partition, workstation or desk



Netfloor SB603 Service Box to install at cable trench. SB603 accommodate 2 X 110 volts power socket, 3 X cat. 5 or cat. 6 data jacks

2. Through Outlet-Panel To Accommodate Large Capacity Outlet Service Box

To accommodate large size outlet box, **Outlet-Panel** is custom-made by cut opening of required size at flank of the UniPanel to accommodate all internationally recognized brand's utility box such as Britmac, VanGeel, Spider, AMP, Powerplan, and etc.



3. Ramp and Skirting (Free Standing)

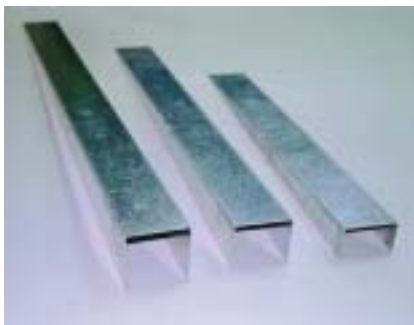

Ramp of 3 heights, 10 cm width



Free Standing of 3 height



Ramp Rail

Ramp: Steel ramp is available in 3 heights 6 cm, 7.6 cm, 10 cm. Length of ramp is minimum 12 times to ramp's height.

Free Standing: Letter F shaped aluminum free standing is also available in 3 heights 6cm, 7.6 cm and 10 cm.

Ramp Rail: 10 cm width aluminum Ramp Rail to Install horizontally at joint line of UniPanel and Ramp.



4. Components For Supporting Cut Panel At Perimeter

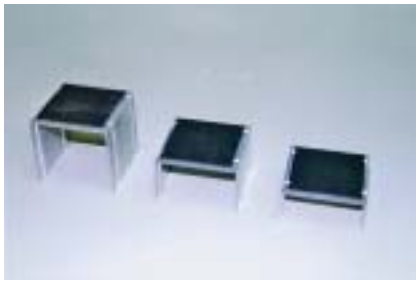

UniPanel Supporter for CR1000



Cut-Panel



Adjustable Supporter for CR1500

5. Components For Residual Installation At Perimeter (CR1000)

L-sharp Edge Rail for perimeter residual less than 8 cm (3.15"), available 3 heights

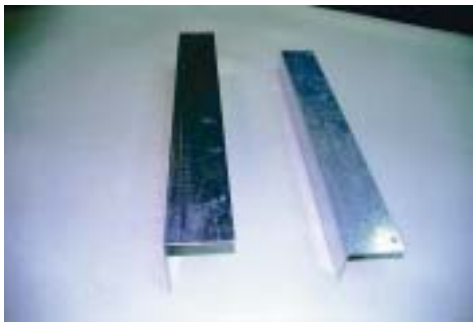

3 standard heights 10, 7.6, 6 cm

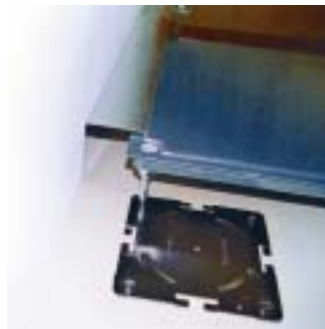

Install when < 8 cm residual between wall and full size UniPanel

6. Starting Cap & Cable Bridge

Starting Cap to cover gap at beginning of cable trench along first row UniPanels



Cable Bridge for cable intersection install on top of Base Connector



STANDARD SYSTEM HEIGHT AND CABLE TRENCH CLEARANCE

CamassCrete® --- CR1000 Systems

CR1000 series are developed especially for where ceiling heights are critically limited. CR1000 series are good solution to install at less than 10 cm (4") height and yet retains sufficient height and room for cable routing under the Cable Trenches. The charts and drawings below show the cable trenches clearance at different heights:

System	System Height	Cable Trench Clearance (A)
CR1000-40	40 mm (1.57")	35 mm (1.38")

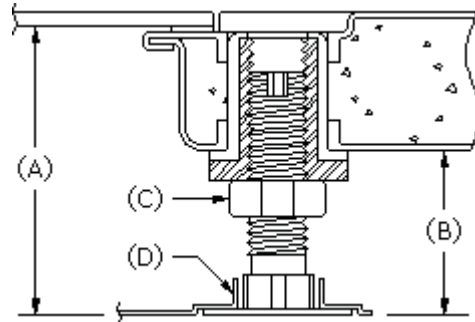

System	System Height	Cable Trench Clearance (A)
CR1000-50	50 mm (1.97")	45 mm (1.77")
CR1000-60	60 mm (2.36")	55 mm (2.16")

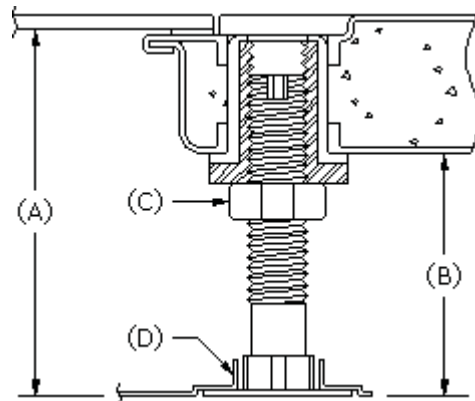

System	System Height	Cable Trench Clearance (A)
CR1000-76	76 mm (3")	71 mm (2.80")
CR1000-100	100 mm (4")	95 mm (3.8")

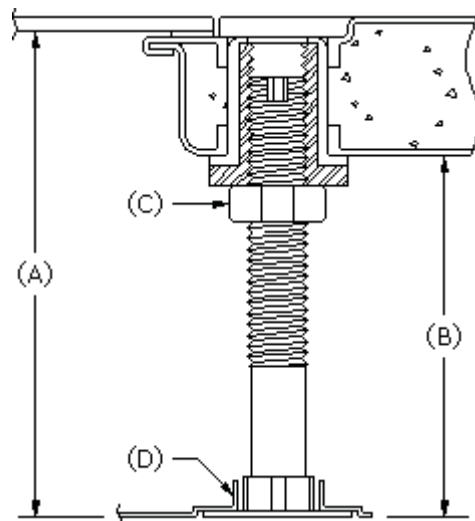

- (A): Clearance at cable trenches
- (B): Clearance under UniPanel: (A) - 28 mm
- (C): Lock-nut
- (D): Base Connector

CamassCrete® --- CR1500 Systems

CR1500 series provides extra large cable management capacity, **CamassCrete®** CR1500 series are ideal flooring system for highly modernized offices such as bank, corporate headquarter, government, and etc.

System	System Height	Cable Trench Clearance (A)
CR1500	100 ~ 150 mm (4" ~ 6")	95 ~ 145 mm (3.8~5.8")

3 heights pedestals 12 cm, 13.5 cm and 15 cm, to fix at the job site.

Pedestal can be adjusted from corner at top of UniPanel (main panel) downward 6 mm and Upward maximum 15 mm.

(A): Clearance at cable trenches

(B): Clearance under UniPanel: (A) - 28 mm

(C): Lock-nut

(D): Base Connector

Installation principle of CR1500 at 10 ~15 cm height same as traditional raised access floor. Laser liner and leveling installation is required.

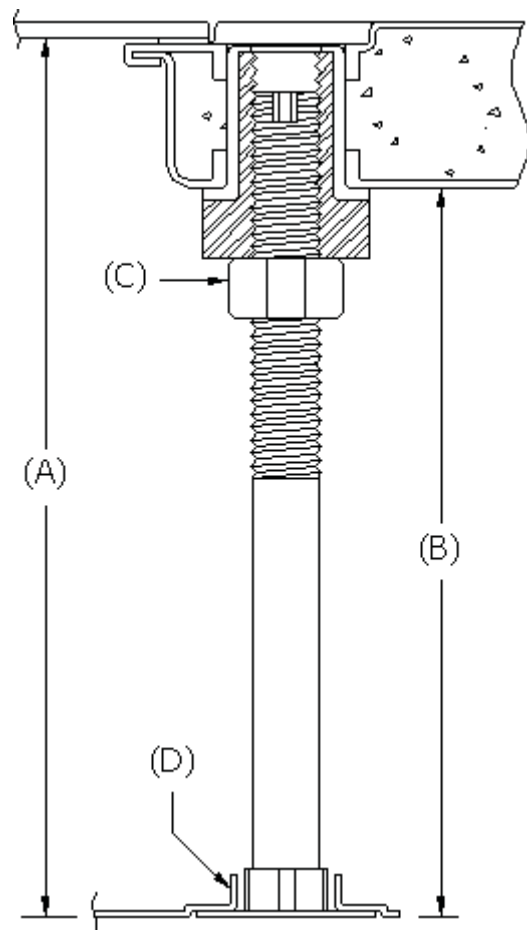

Leveling adjustment: Use 4 mm hex key wrench and adjust height from top.



4mm Hex key wrench adjust from top. 17 mm wrench to loose and fasten the lock-nut of the pedestal when adjusting the height.

WHY CAMASSCRETE® IS THE RIGHT CHOICE IN OFFICE ENVIRONMENT?

Internet and intranet have been developed at an exponential speed. Raised access floors using in the office for cable management purposes becomes a necessity. The conventional raised access floors, which are used mainly for factory purposes have been lightly modified to use in offices lately. Fundamentally, the traditional access floors are not suitable for office environment. The chart below is a comparison of the common issues made between **CamassCrete®** and **Traditional Access Floors**.

" CamassCrete®" vs. "Traditional Access Floors"

	CamassCrete® CR1000 & CR1500	Traditional Access Floors		
Panels	Steel in-filled with cement	Steel in-filled with cement		
Flammability	Non-combustible	Non-combustible		
Module set size	600 mm × 600 mm	600 mm × 600 mm		
Cable Trenches	System height	Clearance	System height	Cable Clearance Under Panel
	40 mm	35 mm	Not suitable	Not suitable
	50 mm	45 mm	Not suitable	Not suitable
	60 mm	55 mm	Not suitable	Not suitable
	76 mm	71 mm	Not suitable	Not suitable
	100 mm	95 mm	Not suitable	Not suitable
Concentration load Depression	450 kg < 2.0 mm (1,000 LB < 2.0 mm)	300 kg ~ 680 kg < 2.0 mm, vary by systems (660 LB ~ 1,500 LB < 2.0 mm)		
Installation speed	30 ~ 40 m ² / man day	30 ~ 40 m ² / man day		
Cable management	Cable trenches 100 mm every 600 mm	No cable trenches, floor cable trunks are needed		
Cable exit	Free extension from cable trenches	Difficult, panels have to be cut		
Outlet panel	Cut to fit outlet box at job site or factory	Cut to fit outlet box at job site or factory		
User friendly	Trench caps can be easily lifted. Self-standing Panel won't cause hazard	Need special tool to lift panel in maintenance. Heavy and loose panel are accident-prone.		
Floor Condition for installation	Need better floor condition, generally leveling needed	Generally leveling isn't necessary, but installation height shall be higher than 10 cm		
Low-profile and / or retrofit installation	Suitable to be installed at 10 ~ 4 cm (4" ~ 1.57") height. Can be installed on top of old rigid loop-pile carpet or sheet vinyl.	Not suitable installing under 10 cm (4"). In case of retrofit project, old carpet or cushion sheet vinyl must be removed.		

SPECIFICATIONS

Module Set: 600 mm × 600 mm (23.6" × 23.6")

Capacity of Cable Trenches: 100 mm width for all **CamassCrete®** systems.

System Height And Cable Trench Capacity:

CamassCrete® CR1000 Series

System	Total Height	Cable Trench Clearance
CR1000-100	100 mm	95 mm
CR1000-76	76 mm	71 mm
CR1000-60	60 mm	55 mm
CR1000-50	50 mm	45 mm
CR1000-40	40 mm	35 mm

CamassCrete® CR1500 Series

CR1500	100 ~ 150 mm	95 ~ 145 mm
--------	--------------	-------------

Main Components

UniPanel (Main Panel): Size 510 x 510 mm (20.07" x 20.07"). Steel, powder coating in-filled with light weight cement.

Pedestals: Galvanized steel, fixed at four corners. Assembled to system's required height.

Central Cap: 2.3 mm thick steel, corrosion resistance protection with powder coating or electro-deposit.

Flank Cap: 2.3 mm thick steel, corrosion resistance protection with powder coating or electro-deposit.

Base Connector: 1.0 mm thick steel, black, electro-deposit or powder coating corrosion protection

Flammability: Non-combustible. Meet BS476, part 4, ASTM E-84 class 1.

Loading property

Concentration Load: 450 kg < 2.0 mm depression (1,000 LB < 2.0 mm depression) in accordance with ASTM E-196

Uniform Distribution Load: Ultimate uniform load > 4,000 kg per sq. meter.

Other tests: Conducting

Quality Assurance: **CamassCrete®** systems are made of first grade materials. Using of refurbished materials is prohibited.

Warranty: 10 years limited warranty. In pursuing quality improvement, the manufacturer reserves the right to vary specifications without prior notice.



PATENT GRANTED

USA: Invention Patent No. 5.630.300

Germany: Utility Model No. 29620106.5

Netherlands: Patent No. 1017802

Russia: Invention Patent No. 22168

England: British Patent No. GB2373796

China: Utility Model No. ZL96200625.4

Japan: Utility Model No. 3032638

Taiwan: Invention Patent No. 127700

South Africa: Invention Patent No. 97/020

----- World-wide patent pending -----